

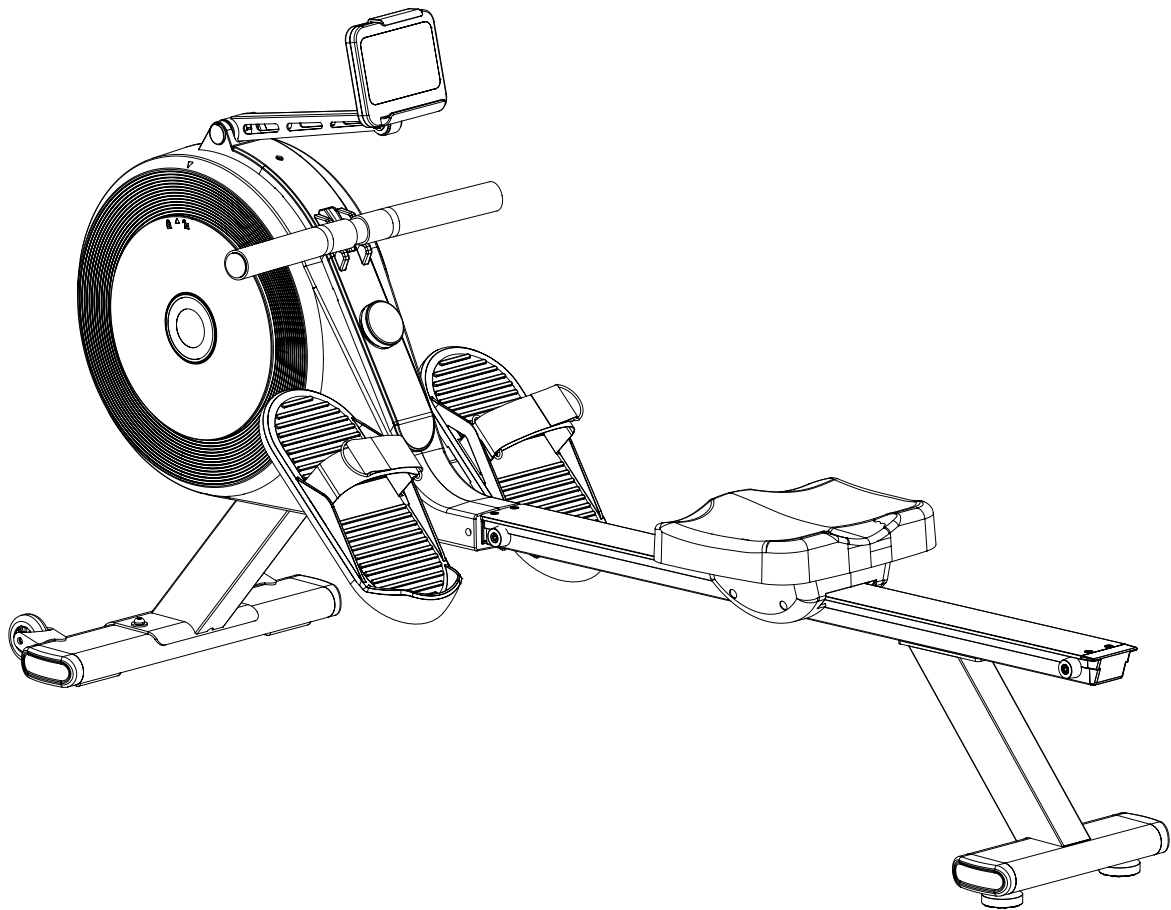

GR4.0 ROWING MACHINE

USER MANUAL



IMPORTANT

Read all instructions carefully before using this product. Retain this owner's manual for future reference. The specifications of this product may vary and are subject to change without further notice.



BEFORE YOU BEGIN

Thank you for choosing Gymstick training equipment. We take great pride in producing this high-quality product and hope it will make you feel better and enjoy life to the fullest. Please read this manual in its entirety before beginning to use this product.



IMPORTANT

Read all instructions carefully before using this product.
Retain this owner's manual for future reference.



WARNING

Read and follow all safety instructions carefully.
Failure to follow safety instructions could result in serious injury.

BEFORE YOU BEGIN	2
SAFETY INSTRUCTIONS	3
EXPLODED DRAWING	4
PARTS LIST	6
ASSEMBLY	7
CLEANING & STORAGE	8
ADJUSTMENT GUIDE	11
CONSOLE OPERATION INSTRUCTIONS	12
IMPORTANT ELECTRICAL INFORMATION	14
CORRECT ROWING METHOD	15
WARM UP & COOL DOWN	16
IMPLIED WARRANTY	18



IMPORTANT

The specifications of this product may vary and are subject to change without further notice.

SAFETY INSTRUCTIONS

Basic precautions should always be followed when using this product. In order to ensure safe read and follow all safety instructions included in this user manual. Failure to do so could result in serious injury.



WARNING

Before using this product, consult your physician first. This is especially important for individuals over the age of 35 or persons with pre-existing health problems.

1. Keep children and pets away from the Rowing Machine at all times. Do not leave unattended children in the same room with the machine.
2. Handicapped or disabled persons should not use the Rowing Machine without the presence of a qualified health professional or physician.
3. If the user experiences dizziness, nausea, chest pain, or any other abnormal symptoms, stop the workout at once. Consult Physician immediately.
4. Before beginning training, remove all within a radius of 2 meters from the machine. Do not place any sharp objects around the Rowing Machine.
5. Position the Rowing Machine on a clear, level surface away from water and moisture. Place mat under the unit to help keep the machine stable and to protect the floor.
6. Use the Rowing Machine only for its intended use as described in this manual. Do not use any other accessories not recommended by the manufacturer.
7. Assemble the machine exactly as the descriptions in the instruction manual.
8. Check all bolts and other connections before using the machine for the first time and ensure that the trainer is in the safe condition.
9. Hold a routine inspection of the equipment. Pay special attention to components which are the most susceptible to wear off, i.e. connecting points and wheels. The defective components should be replaced immediately. The safety level of this equipment can only be maintained by doing so. Please don't use the Rowing Machine until it is repaired well.
10. Never operate the Rowing Machine if it is not functioning properly.
11. This machine can be used for only one person's training at a time.
12. Do not use abrasive cleaning articles to clean the machine. Remove drops of sweat from the machine immediately after finishing training.
13. Always wear appropriate workout clothing when exercising. Running or aerobic shoes are also required.
14. Before exercising, always do stretching first.
15. It is the responsibility of the owner to ensure that all users are properly informed as how to use this product safely.
16. This machine is intended for home use.
17. Maximum user weight 120 kgs.

EXPLODED DRAWING

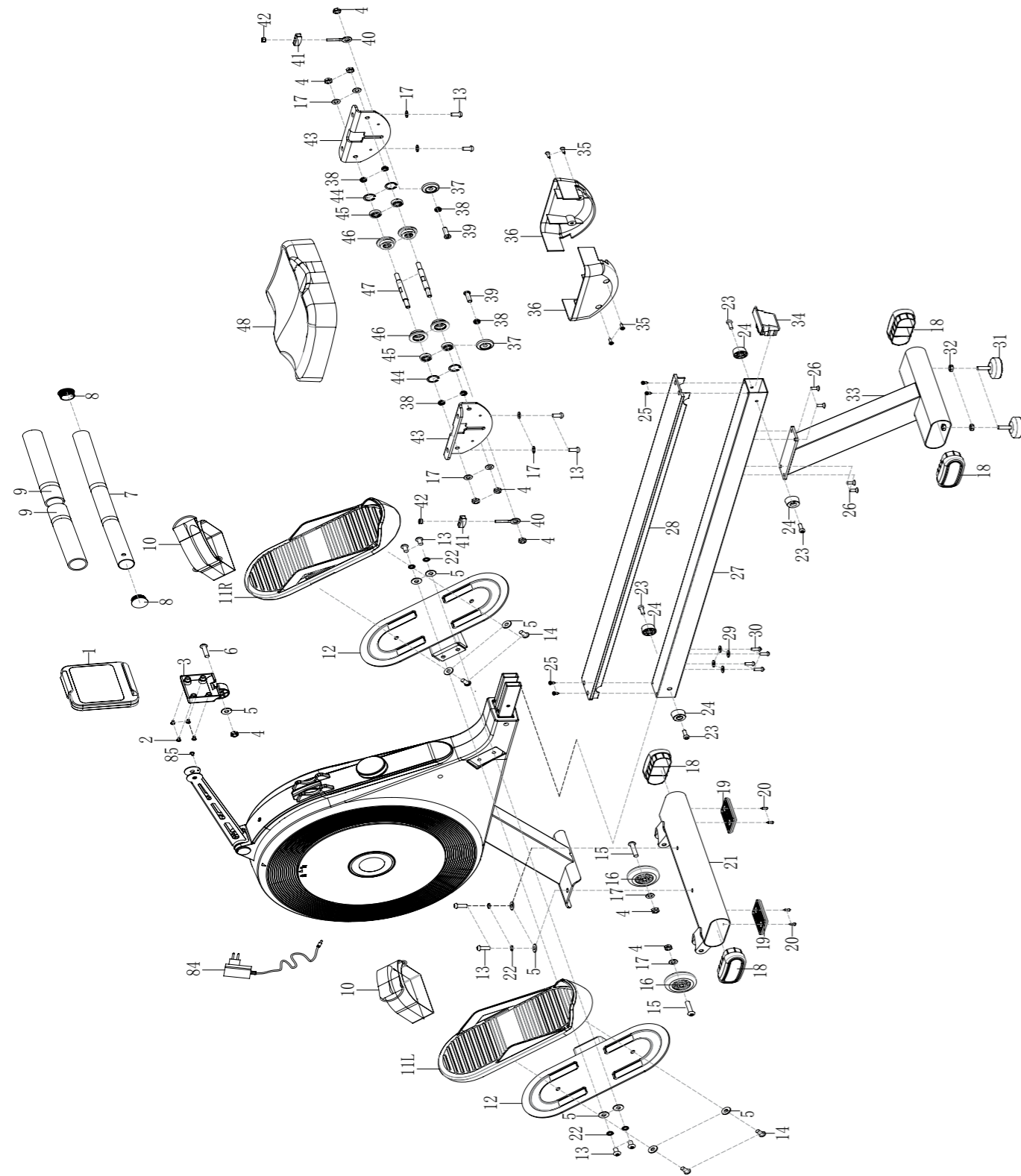



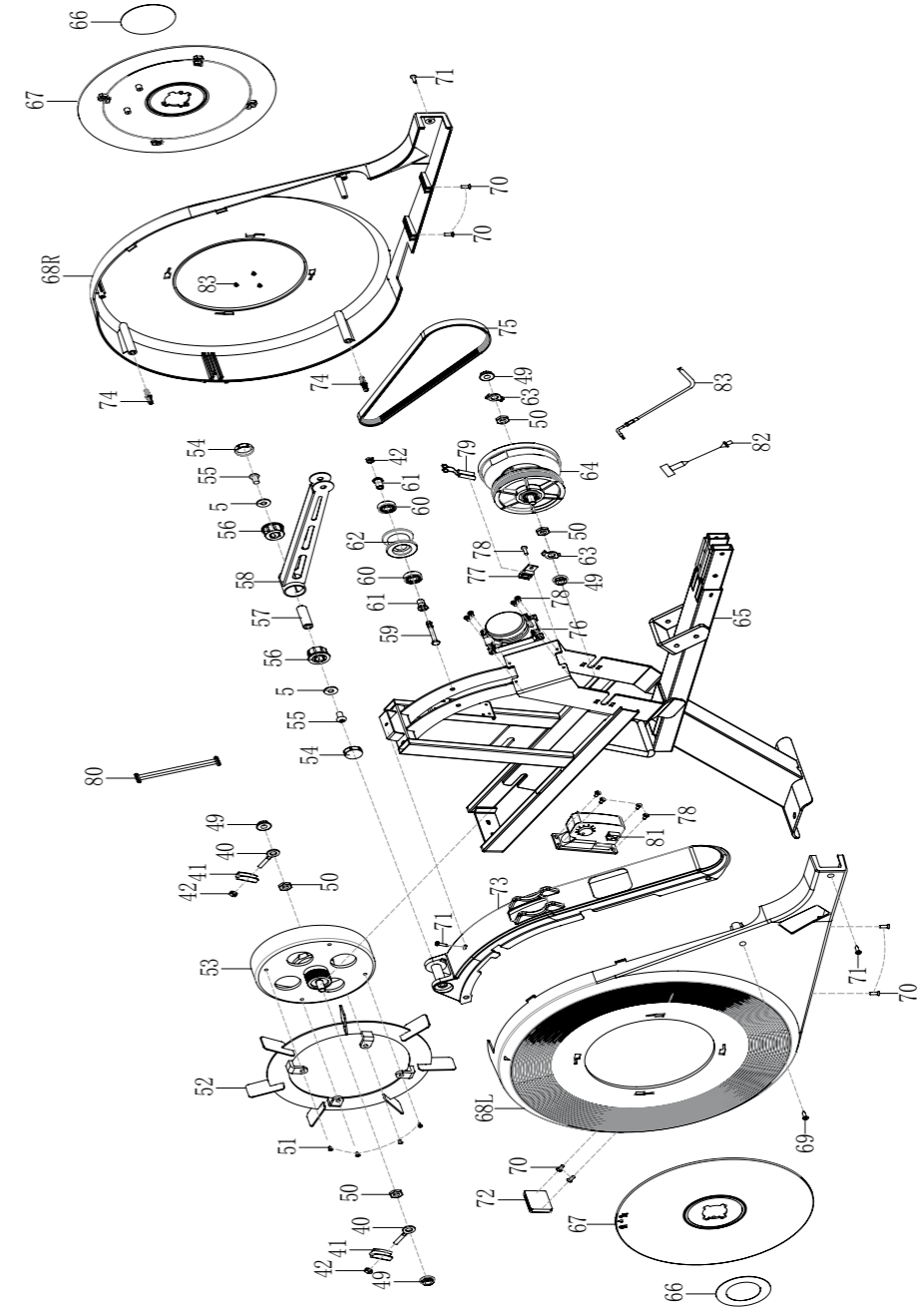











EXPLODED DRAWING



PARTS LIST

No.	Description	Qty	No.	Description	Qty
1	Tablet holder	1	45	Bearing 608ZZ	4
2	Bolt M5*20	4	46	Roller Φ36*14	4
3	Fixed holder for tablet	1	47	Seat shaft Φ10*118	2
4	Nylon nut M8*H7.5*S13	9	48	Seat	1
5	Washer d8*Φ20*2	13	49	Nut M10*1*H8*S15	4
6	Bolt M8*35*18*S5	1	50	Nut M10*1*H5*S17	4
7	Handlebar	1	51	Bolt M6*10*S5	4
8	Round end cap Φ28*15	2	52	Fan wheel	1
9	Foam grip	2	53	Flywheel	1
10	Pedal strap	2	54	Cover	2
11	Pedal (L&R)	1	55	Bolt M8*16*S5	2
12	Pedal plate	2	56	Bushing	2
13	Bolt M8*20*S5	10	57	Shaft	1
14	Bolt M8*16*S5	4	58	Tablet holder post	1
15	Bolt M8*42*15*S5	2	59	Bolt M6*55*15*S10	1
16	Transportation wheel	2	60	Bearing 6000	2
17	Washer d8*Φ16*1.5	10	61	Spacer	2
18	End cap	4	62	Mesh belt Wheel	1
19	Non-slip mat	2	63	Fixed plate	2
20	Screw ST4.0*19*Φ11	4	64	Mesh belt plate	1
21	Front stabilizer	1	65	Main frame	1
22	Spring washer d8	6	66	Sticker	2
23	Bolt M6*20*S5	4	67	Turntable	2
24	Rubber pad	4	68 L/R	Chain cover	1
25	Bolt M5*10*Φ9	4	69	Screw ST4.2*19*Φ8	1
26	Bolt M6*15*S4	4	70	Screw ST4.8*19*Φ8	6
27	Sliding rail	1	71	Screw ST4.2*16*Φ8	3
28	Alum plate	1	72	Support pad	1
29	Washer 6*Φ16*1.5	4	73	Upper cover	1
30	Bolt M6*15*S5	4	74	Connector	2
31	Adjustable pad	2	75	Belt	1
32	Nut M8*H5.5*S14	2	76	Computer	1
33	Rear stabilizer	1	77	Sensor holder	1
34	Rail cover	1	78	Screw ST4.2*8*Φ8	9
35	Bolt M5*12*Φ10	4	79	Sensor	1
36	Seat cover	2	80	Trunk wire	1
37	Roller Φ35*Φ8*11	2	81	Motor	1
38	Spacer Φ12.5*Φ8.2*4.5	6	82	Power trunk wire	1
39	Bolt M8*28*10*S5	2	83	Tension wire	1
40	Adjustable bolt M6*40	4	84	Adapter	1
41	Adjustable U seat	4	85	Screw M4*6	1
42	Nylon nut M6*H6*S10	5			
43	Seat plate	2			

HARDWARE LIST

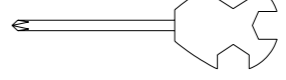
 #2 M5*20	4 pcs	 #24 Φ27*Φ23*16*Φ6	4 pcs
 #4 M8*H7.5*S13	1 pc	 #25 M5*10* Φ9	2 pcs
 #5 D8* Φ20*2	7 pcs	 #26 M6 *15*S4	4 pcs
 #6 M8*35*S5	1 pc	 #29 D6* Φ16*1.5	4 pcs
 #13 M8*20*S5	6 pcs	 #30 M6*15*S5	4 pcs
 #22 D8	6 pcs	 #A S4	1 pc
 #23 M6*20*S5	4 pcs	 #B S5	1 pc
		 #C S13-14-15	1 pc



IMPORTANT

Before assembly, please ensure all parts are included in the package. In case any parts are missing, contact our customer service to resolve the issue.

ASSEMBLY

The product assembly process has been documented in easy to follow steps. Please read all assembly instructions carefully. Take time to review the manual and familiarize yourself with the entire assembly process before proceeding.

Do not dispose of any packaging materials until assembly of the product is completed.

This machine must be assembled by adults.

STEP 1.

Attach front stabilizer (21) to main frame (65) using bolts (13), spring washers (22), and washers (5). Tighten and secure with Allen wrench (B).

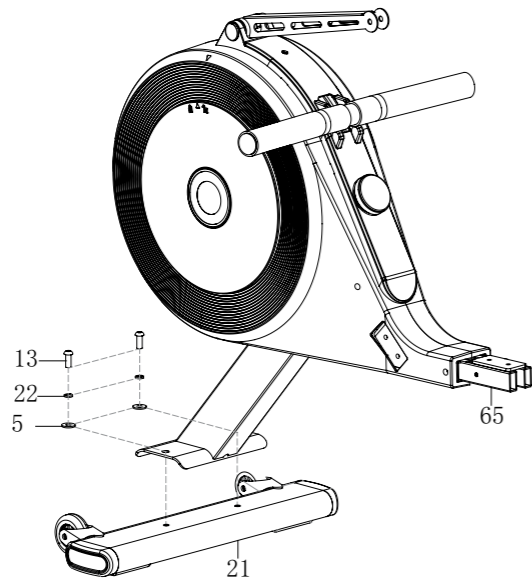

STEP 2.

Attach rear stabilizer (33) to sliding rail (27) using bolts (26). Tighten and secure with Allen wrench (A).

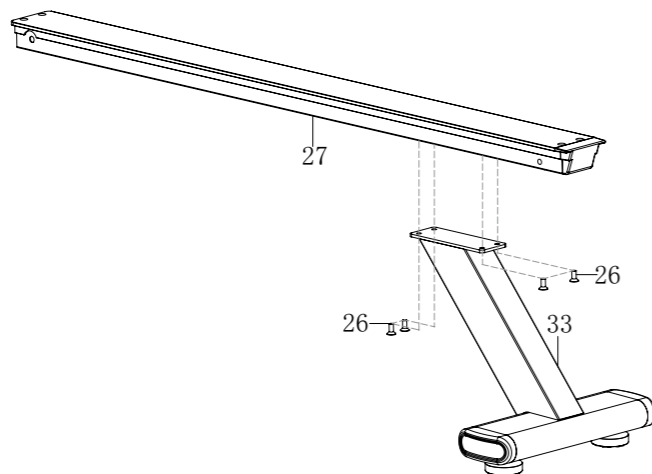

ASSEMBLY

STEP 3.

- A. Attach sliding rail (27) to main frame (65) using bolts (30) and washers (29). Tighten and secure with Allen wrench (B).
- B. Secure alum plate (28) into sliding rail (27) using screws (25) with wrench (C).
- C. Secure rubber pad (24) in sliding rail (27) using bolts (23) with Allen wrench (B).

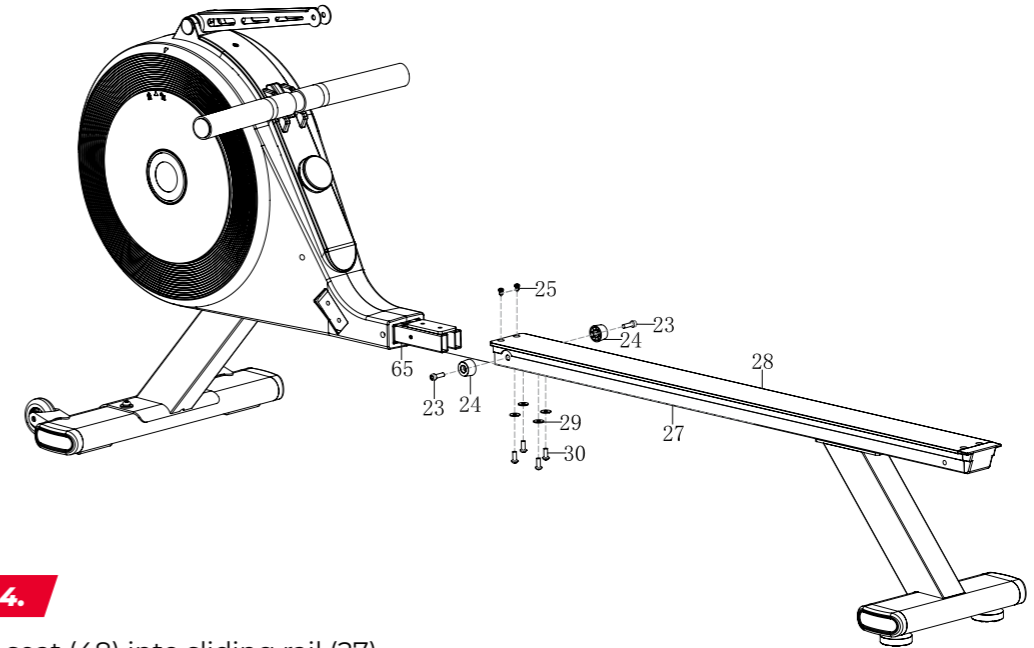

STEP 4.

- A. Insert seat (48) into sliding rail (27).
- B. Secure rubber pad (24) in sliding rail (27) using bolts (23) with Allen wrench (B).
- C. Attach pedal (11L/R) into main frame (65) using bolts (13), spring washers (22) and washers (5). Tighten and secure with Allen wrench (B).

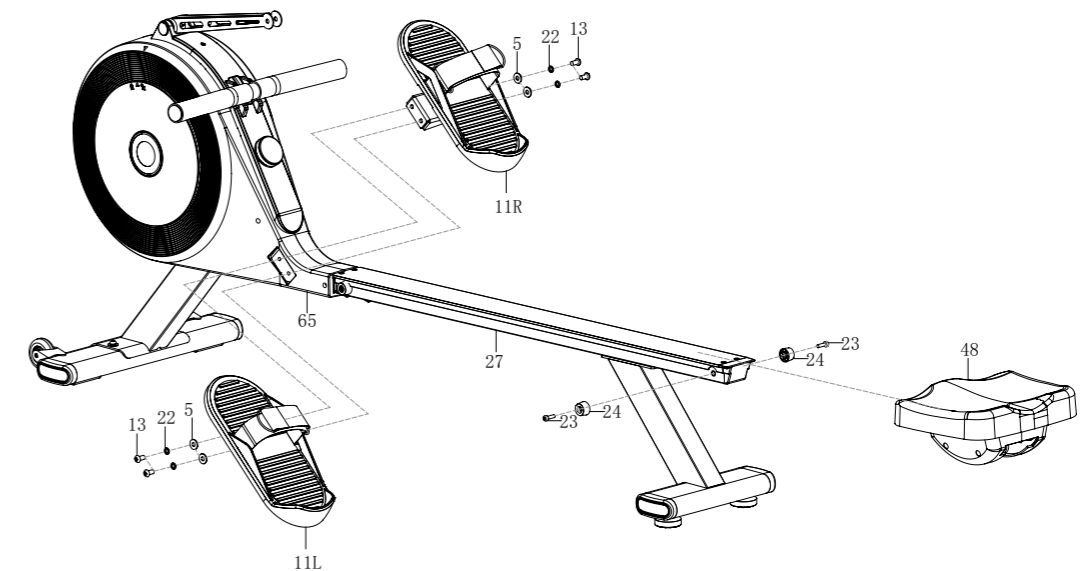

Note! Make sure to turn bolts (13) clockwise with Allen wrench (B) as tightly as you can with your hand, to secure pedal (11L/R) with main frame (65) well.

ASSEMBLY

STEP 5.

- A. Unlock screw (85) from Tablet holder post (58) by wrench (C).
- B. Secure Fixed holder of Tablet holder (3) with Tablet holder post (58) with bolt (6), nylon nut (4) and washer (5) by Allen wrench (B) and wrench (C).
- C. Secure Tablet holder (1) in the Fixed holder of Tablet (3) with bolts (2) by wrench (C).
- D. Secure screw (85) on the Tablet holder post (58) by wrench (C).
- E. Insert adapter wire (84) to power hole on the main frame (65), then plug the adapter into an outlet.

The assembly is complete!

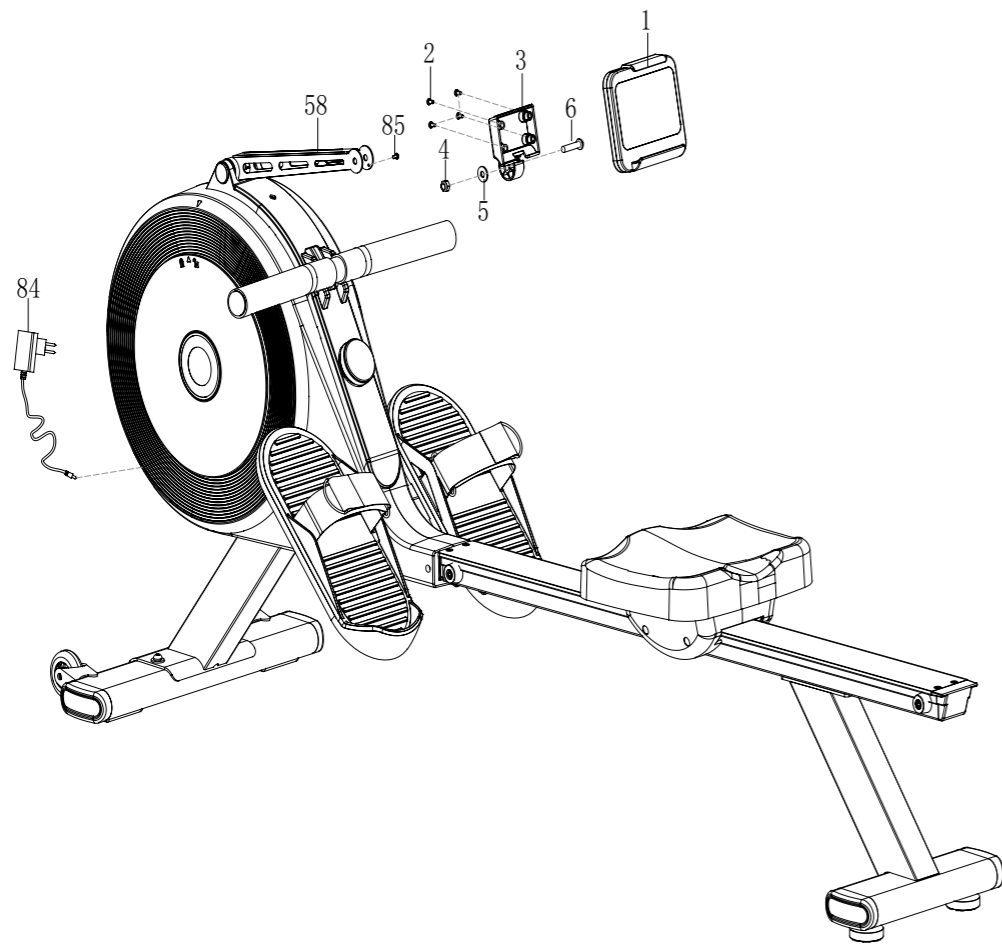

CLEANING & STORAGE

The device can be cleaned with a soft cloth and mild detergent. Do not use abrasives or solvents on any parts. Please wipe your perspiration off the device. Please keep the device out of direct sunlight. Store the device in a clean, warm and dry environment away from children.

Lubricate moving parts with WD-40 or other light oil periodically.

ADJUSTMENT GUIDE

PEDAL ADJUSTMENT

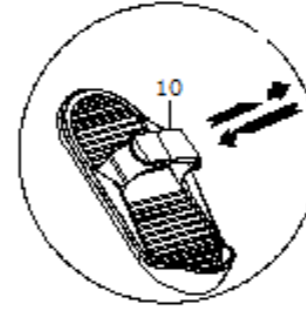

The pedal strap (10) is adjustable and can be personalized to fit the user's foot size.

TABLET ANGLE ADJUSTMENT

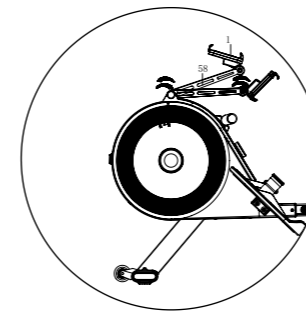

The rotation angle of Tablet holder (1) and Tablet holder post (58) can be adjusted to obtain the best view of the iPad/smart phone LCD screen.

MOVING THE MACHINE

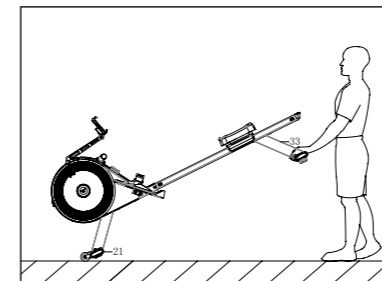

To move the machine, lift up the rear stabilizer (33) until the transportation wheels (16) touch the ground. With the wheels on the ground, you can transport the machine to the desired location with ease.

STORAGE

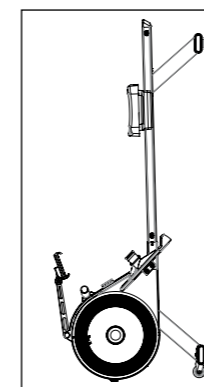

When not in use, you can stand up the machine to save the space.

CONSOLE OPERATION INSTRUCTIONS



DESCRIPTION OF DISPLAY

- Scanning mode: Display in the following order successively for every 6 seconds: (Time -> Distance -> Resistance Level -> Strokes -> Calories -> Bluetooth)
- Press the knob of Display to select and fix a certain function, and then display it on the main window.
- Console has 32-resistance levels.

	Function	Description	Range
	Time	Time of exercise	0 min: 00 s ~ 99 min: 59 s
	Distance	Distance of exercise	0.00 ~ 99.99 km
	Resistance level	Resistance level of exercise	1 ~ 32
	Strokes	Number of strokes: Statistics of the number of strokes during exercise	0 ~ 9999
	Calories	Energy consumed during exercise	0.0 ~ 999.9 kcal
	Bluetooth & App	Support that APP is controlled via Bluetooth. When there is Bluetooth equipment connected, the icon is displayed	

BUTTON FUNCTIONS

Start or stop the exercise: Press the middle of knob is to start or stop the exercise.

Start: Press the middle of knob to start the exercise and turn on display.

Stop: During display working, press the knob 1 second to switch the display. Keep pressing the knob 3 seconds to pause the workout, until it displays "PAU".

CONSOLE OPERATION INSTRUCTIONS

- In the paused state, press 1 second to un-pause and continue counting.
- In the paused state, press 3 seconds and the previous data will be cleared.

- Increase the resistance: Rotate the knob clockwise to increase the resistance level during exercise.
- Decrease the resistance: Rotate the knob counterclockwise to decrease the the resistance level during exercise.

SLEEP AND AUTOMATIC PAUSED MODE

- When in use, and there is no speed signal within 4 minutes, the display will be enter paused mode automatically.
- Without any operation, the product will enter sleep mode after 10 minutes.
- Press the knob to stop the paused mode.
- At any time, the system can be shut down by turning off the power plug, the system will not be damaged.

CALORIES CALCULATE METHOD

Calories are calculated at 15 calories per kilometer. When there is no speed signal, calories and distance will be not counted.

NOTE!

1. This instrument requires a power adapter. When the instrument displays abnormally, please unplug and then plug in the power plug again.
2. Without any operation, the product will enter sleep mode after ten minutes.

BLUETOOTH FUNCTION

This device is equipped with an integrated Bluetooth® connectivity which allows it to work with interactive applications such as KinoMap and Swift.



- a) Download Kinomap APP from AppStore (iOS) or Google Play (Android).
- b) Enable bluetooth from your phone or tablet settings.
- c) Run the Kinomap APP.
- d) Go to the "My equipments" menu and tap on the "+" button.
- e) Follow the instructions on the APP to complete the connection.
- f) Once connection is established the bluetooth icon on the display will be ON.



IMPORTANT

Turn off the device if you are not going to use it for a long time.

IMPORTANT ELECTRICAL INFORMATION

	GR4.0 ROWING MACHINE		 <small>WARNING - To reduce the risk of personal injury, read and understand all the instructions before using this product.</small>
	Model No. : RW-GR4.0 Maximum Load : 120 kg Made in : China Manufactured for : Gymstick International Oy Address : Ratavirtijankatu 11 15170 Lahti, Finland	SN: 011223RWGR400001	



WARNING

This machine requires a right power source in order to properly operate. For your safety, as well as the safety of others, please verify that the power source is correct before plugging the equipment. Any incorrect power source could cause significant damage to the equipment and or user.

POWER SOURCE

Power source requires mains power and a correct power adapter. Adapter specifications:

Input: 100-240V 50/60Hz
 Output: 12V 1.0A

GROUNDING METHODS

This product must be grounded. Grounding provides the least resistance for electrical current and will reduce the risk of electric shock. The plug must be plugged into an appropriate outlet that is properly installed and grounded in accordance with all local codes and ordinances.



WARNING

Improper connection of the equipment-grounding conductor can result in risk of electric shock. Check with a certified electrician if you are in doubt as to whether the product is properly grounded.



IMPORTANT

Never expose the machine to rain or moisture. This machine is not designed for use outdoors, near pools or in any other high humidity environment.

CORRECT ROWING METHOD

There are three rowing actions: catch, slide and recovery. However, for the coherence of actions, these two actions usually are mixed together. No pause shall exist during rowing. We suggest someone observe your driving and compare your position with that in the picture. Wrong exercise method may cause bodily harm.

START POSITION

Place your feet on the footrests and hold the bar firmly. Pull your body to the starting position. Keep your back and arms straight.

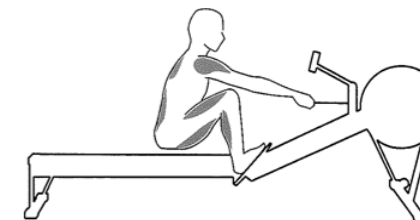

Remember that your body will never stop suddenly.

SLIDE

During the rowing process, the user straightens the legs, and slides backwards on the seat. During the rowing process, the arms should still be straight and the shoulders should be relaxed.

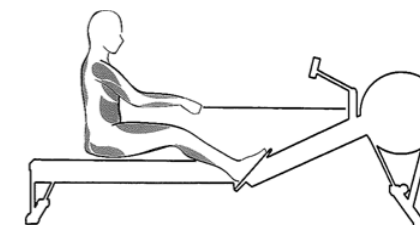

RECOVERY

At the end of the rowing process, pull the handles towards your stomach with the strength of your arms and shoulders. The legs are straight and the body leans back a little. Note that the height of the handles is not at chest or knee height.

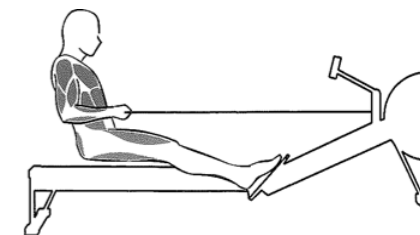

SLIDE

Extend your arms, swing your body forward, support the pelvis and start the recovery. In this way, the handles can be placed in front of the knees to avoid mutual interference of knees and hands when the seat moves forward.

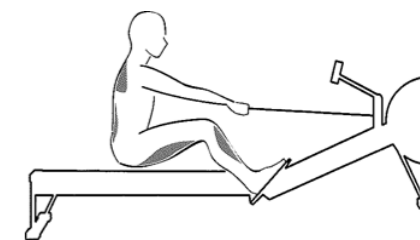

CATCH

The rower bends his knees, stretches his arms and leans his body towards the flywheel. All the power is concentrated in the legs and back. Keep rowing.

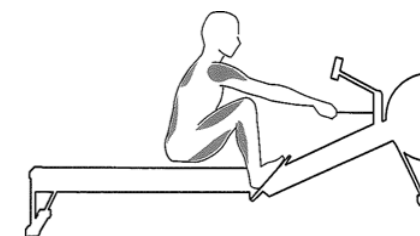

Note! Arms shall be straight, and shoulders shall be relaxed.

WARM UP & COOL DOWN

Exercise in any form is one of the best things you can do for your overall health. A good exercise program consists of a warm-up, actual workout and a cool down.

AEROBIC EXERCISE is any sustained activity that sends oxygen to your muscles via your heart and lungs. Aerobic exercise improves the fitness of your lungs and heart. Aerobic fitness is promoted by any activity that uses your large muscles eg: legs, arms and buttocks. Your heart beats quickly and you breathe deeply. An aerobic exercise should be part of your entire exercise routine.

The WARM-UP is an important part of any workout. It should begin every session to prepare your body for more strenuous exercise by heating up and stretching your muscles, increasing your circulation and pulse rate, and delivering more oxygen to your muscles.

COOL DOWN at the end of your workout, repeat these exercises to reduce soreness in tired muscles.

Do the entire program at least two to three times a week, resting for a day between workouts. After several months you can increase your workouts to four or five times per week.



HEAD ROLLS

Rotate your head to the right for one count, feeling the stretch up the left side of your neck, then rotate your head back for one count, stretching your chin to the ceiling and letting your mouth open. Rotate your head to the left for one count, then drop your head to your chest for one count.



SHOULDER LIFTS

Lift your right shoulder toward your ear for one count. Then lift your left shoulder up for one count as you lower your right shoulder.



SIDE STRETCHES

Open your arms to the side and lift them until they are over your head. Reach your right arm as far toward the ceiling as you can for one count. Repeat this action with your left arm.

WARM UP & COOL DOWN



QUADRICEPS STRETCH

With one hand against a wall for balance, reach behind you and pull your right foot up. Bring your heel as close to your buttocks as possible. Hold for 15 counts and repeat with left foot.



INNER THIGH STRETCH

Sit with the soles of your feet together and your knees pointing outward. Pull your feet as close to your groin as possible. Gently push your knees toward the floor. Hold for 15 counts.



TOE TOUCHES

Slowly bend forward from your waist, letting your back and shoulders relax as you stretch toward your toes. Reach as far as you can and hold for 15 counts.



HAMSTRING STRETCHES

Extend your right leg. Rest the sole of your left foot against your right inner thigh. Stretch toward your toe as far as possible. Hold for 15 counts. Relax and then repeat with left leg.



CALF/ACHILLES STRETCH

Lean against a wall with your left leg in front of the right and your arms forward. Keep your right leg straight and the left foot on the floor; then bend the left leg and lean forward by moving your hips toward the wall. Hold, then repeat on the other side for 15 counts.

IMPLIED WARRANTY

The importer of this product assures that this device is manufactured with high quality materials. The implied warranty is valid for 1 (one) year, beginning from the date of purchase. The guarantee is valid for home use.

The warranty applies to the following parts:

- Frame
- All parts included in the original delivery

The warranty does not cover:

- Incorrect installation
- Damage caused externally
- Failure to carry out regular maintenance and servicing
- Improper use and handling of the equipment
- Improper storage of the equipment
- Non-compliance of the operating instructions
- Wear parts and expendable parts

MANUFACTURED FOR

Gymstick International Oy
Ratavartijankatu 11
15170 Lahti, FINLAND

DISCLAIMER

The manufacturer and its associates and partners have no liability, obligation or responsibility to any person or entity for any loss, damages or adverse consequence alleges to have happened directly or indirectly as a consequent of this product.



Products marked with these symbols must be disposed of separately from your household waste, as they contain valuable materials which can be recycled. Proper disposal protects the environment and human health. Your local authority or retailer can provide more information on the matter.

